

SPECIFICATION

For 4-wire Analog Touch Panel

Issued : January, 21, 2008 (Ver.0)

DT TEAM	PREPARE	CHECK	APPROVE	QM TEAM	PREPARE	CHECK	APPROVE	

MODEL NO. MD1021M-AB

APPROVED BY

1. Range of Application

This specification is applied to **meeredp** Product No. MD102IM-AB.

2. Warranty

Touch Panel products manufactured to this specification shall be warranted for a minimum period of 12 months from the date of shipping from **meeredp** when stored or used as specified under normal conditions within the contents of these sheets.

If Touch Panel products are not stored or used as specified herein, The 12 month – warranty will be void.

3. Shape

Shape, structure and Dimension are referred to the proper Drawing No. MD102IM-MCD-AB.

4. Rating

4.1 Maximum voltage and current

Less than DC7V, 1mA at the contact point of top layer and bottom layer

4.2 Operation temperature

From -20°C to +70°C (humidity: from 20%RH to 90%RH)

4.3 Storage temperature

From -40°C to +80°C (humidity: from 20%RH to 90%RH)

5. Electrical

5.1 Terminal resistance unit of measurement

Between X1 and X2 (top layer) : 200 ~ 900 Ω

Between Y1 and Y2 (bottom layer): 200 ~ 900 Ω

5.2 Linearity

X axis : ±1.5% or less

Y axis : ±1.5% or less

* Measurement as per attached Appendix 1.

5.3 Insulation resistance

Minimum 20MΩ at DC25V

5.4 Chattering Time

10msec or less at 100kΩ pull-up

we touch the future

meeredp

6. Mechanical performance

6.1 Input method

R0.8 stylus or finger

6.2 Actuation force

Input with stylus : 100g or less (R0.8 Polyacetal stylus)

Input with finger : 100g or less (R8.0 Hs40 silicon rubber)

6.3 Transparency

80% or more

(Measuring apparatus : Haze meter—made by NIPPON DENSYOKU IND.
according to JIS-K7105)

6.4 Surface hardness

Pencil hardness 3H or more according to JIS-K5400.

7. Reliability

7.1 Exposure to high temperature

Put it in a vessel at the condition of 80°C for 240 hours, and then leave it at room temperature for 24 hours or more.

The measurement must satisfy the following:

- ▶ Resistance between terminals: According to Section 5.1
- ▶ Linearity: According to Section 5.2
- ▶ Insulation Resistance: According to Section 5.3
- ▶ Chattering Time: According to Section 5.4

7.2 Exposure to low Temperature

Put it in a vessel at the condition of -40°C for 240 hours, and then leave it at room temperature for 24 hours or more.

The measurement must satisfy the following:

- ▶ Resistance between terminals: According to Section 5.1
- ▶ Linearity: According to Section 5.2
- ▶ Insulation Resistance: According to Section 5.3
- ▶ Chattering Time: According to Section 5.4

7.3 Exposure to constant high temperature and high humidity

Put it in a vessel at the condition of 60°C,90%RH for 240 hours, and then leave it at room temperature for 24 hours or more.

The measurement must satisfy the following:

- ▶ Resistance between terminals: According to Section 5.1
- ▶ Linearity: According to Section 5.2
- ▶ Insulation Resistance: According to Section 5.3
- ▶ Chattering Time: According to Section 5.4

7.4 Repetition of high and low temperature

Put it in a vessel at the condition of -40°C for 30 minutes and then 80°C for 30 minutes. This process is repeated 10 cycles.

Then it is left at room temperature for 24 hours or more.

The measurement must satisfy the following:

- ▶ Resistance between terminals: According to Section 5.1
- ▶ Linearity: According to Section 5.2
- ▶ Insulation Resistance: According to Section 5.3
- ▶ Chattering Time: According to Section 5.4

8. Durability

8.1 Writing friction

Write 120,000 capital or small alphabetical characters with a stylus in an area $20\text{mm} \times 20\text{mm}$.

Stylus is used as below on the following conditions:

Pen: 0.8R Polyacetal stylus Loads : 250gf
Speed: 1,000 characters/hour Measurement Position: Center of Panel

The measurement must satisfy the following:

- ▶ Resistance between terminals: According to Section 5.1
- ▶ Linearity: According to Section 5.2
- ▶ Insulation Resistance: According to Section 5.3
- ▶ Chattering Time: According to Section 5.4

8.2 Finger touches

Punching 1,000,000 times with a silicon rubber R8.0, hardness of 70.

Force : 250g , Speed : 2 Times a second

The measurement must satisfy the following:

- ▶ Resistance between terminals: According to Section 5.1
- ▶ Linearity: According to Section 5.2
- ▶ Insulation Resistance: According to Section 5.3
- ▶ Chattering Time: According to Section 5.4

8.3 Impact resistance

No breakage when $\Phi 19\text{mm}$ steel ball is dropped on the touch panel supported with the display module from 15cm height 1 time.

8.4 Press resistance

No breakage when R8.0, hardness of 70 silicon rubber set on the end of steel bar with 10kg force presses the center of the touch panel with the display module at a speed of 50mm/min.

8.5 Flexible tail peeling strength

400g/cm or more

(peeling upward by 90° deg. in the direction of X, speed: 50mm/min)

8.6 Against Vibration

Applying 50 ~ 200Hz each xyz axis for 1 hour

9. Cosmetic inspection criterion

The followings are applied to the viewing area only. Those in the non-viewing area are ignored as long as the electrical performance of the touch panel is normal. W=Width, L=Length, t=Glass thickness. Contamination that can be cleaned using a soft cloth with ethyl alcohol does not apply to these inspection criterion. But if an object is in the viewing area after rubbed by the soft cloth to a direction 3 times longer, it is considered a linear foreign object.

► Inspection condition

The inspection shall be performed by using two 14W fluorescent lamps.

The panel shall be placed at 30cm away from eyes as shown below.

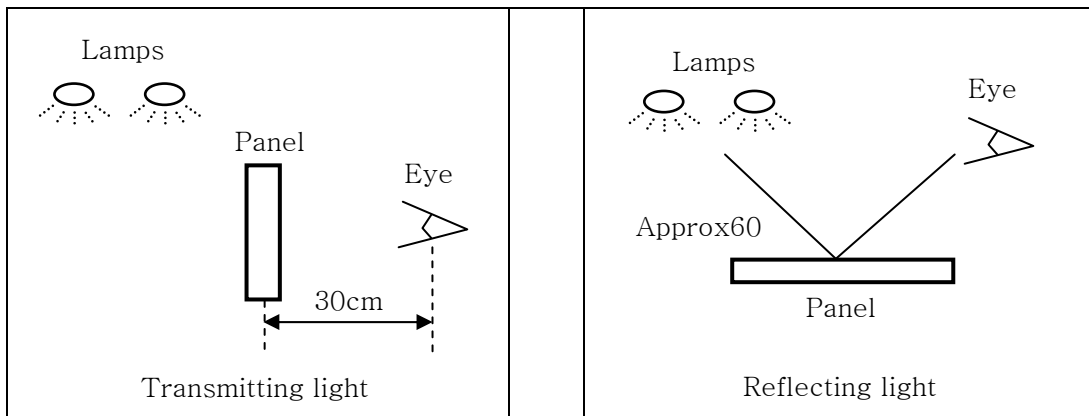

9.1 Spots And Dots

Inspection Method	Criteria
$D \leq 0.2\text{mm}$	Ignored
$0.2\text{mm} < D \leq 0.3\text{mm}$	$N \leq 3$ or less (distance 5mm over)
$D > 0.3\text{mm}$	None
<p>The diagram shows an oval shape with a horizontal dimension line labeled 'X' and a vertical dimension line labeled 'Y'. To the right of the oval is the formula $(X+Y)/2=D$.</p>	

9.2 Liner Foreign Matter & Scratch

Inspection Method	Criteria
$W \leq 0.05\text{mm}$, $L \leq 0.3\text{mm}$	Ignored
$0.05\text{mm} < W \leq 0.1\text{mm}$, $0.3\text{mm} < L \leq 2.0\text{mm}$	$N \leq 3$ or less (distance 5mm over)
$W > 0.10\text{mm}$, $L > 2\text{mm}$	None

9.3 Fish Eye & Bubble

Inspection Method	Criteria
$D \leq 0.10\text{mm}$	Ignored
$0.1\text{mm} < D \leq 0.3\text{mm}$	$N \leq 3$ or less (distance 5mm over)
$D > 0.3\text{mm}$	None

9.4 Newton's Ring

Inspection Method	Criteria
$D \leq 8\text{mm}$, $a > 10\text{mm}$	Ignored
$D > 8\text{mm}$, $a \leq 10\text{mm}$	None

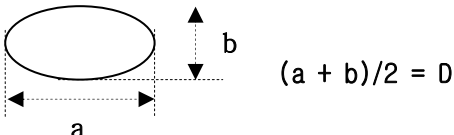

$(a + b)/2 = D$

9.5 Film Bagginess

Inspection Method	Criteria
$D \leq 0.4\text{mm}$	Ignored
$D > 0.4\text{mm}$	None

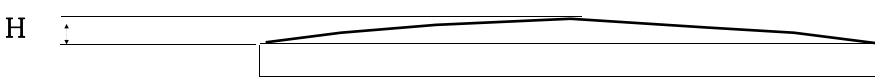

H :

9.6 Glass breakage

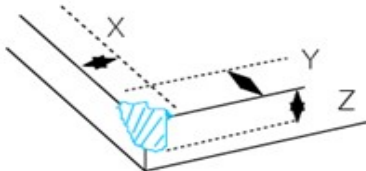
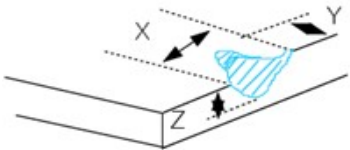
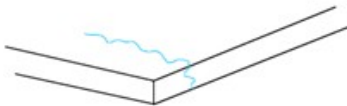
	Criteria		
Corner Crack		$X \leq 2.0\text{mm}$ $Y \leq 2.0\text{mm}$ $Z \leq t$: Ignored
General Crack		$X \leq 3.0\text{mm}$ $Y \leq 2.0\text{mm}$ $Z \leq t$: Ignored
Bad Crack		All shall be rejected. : None By naked eyes.	

10. Inspection

10.1 Resistance between terminals

Criterion : According to Section 5.1.
All the T/Ps are inspected.

10.2 Linearity

Criterion : According to Section 5.2.
All the T/Ps are inspected.

10.3 Insulation resistance

Criterion : According to Section 5.3.
All the T/Ps are inspected in the first production lot.
Sampling inspection from the second lot.

10.4 Appearance

Criterion : According to Section 9.
All the T/Ps are inspected.

11. Handling Remarks

SUBJECT	NOTE
Storage	<ul style="list-style-type: none"> ① Store touch panels in boxes at storage temperature. ② Please do not expose touch panels to a direct ray of the sun.
Unpacking	<ul style="list-style-type: none"> ① Open the box after checking the up/down indicator. ② Please do not touch where tails are heat-sealed in order to avoid disconnection.
Handling	<ul style="list-style-type: none"> ① Use gloves and masks when handling touch panels. ② Please do not touch where tails are heat-sealed in order to avoid disconnection. ③ Hold touch panels around outside of viewing area. ④ Please do not pile touch panels onto other touch panels. ⑤ Please do not put heavy objects on touch panels. ⑥ Clean off touch panels with soft clothes with alcohol when surface is dirty. ⑦ Please do not use organic solvents except alcohol.
Assembly	<ul style="list-style-type: none"> ① Please design housing which minimizes stress onto touch panels. ② Please pay attention not to harm touch panels with your tools which may be used for assembling. ③ Please pay attention not to create any stress to the heat-sealed tails.
Housing design	<ul style="list-style-type: none"> ① Keep the gap (over 0.3mm) between the touch panel and flat-panel display to protect a display device. The reason is to prevent the bezel edge from contacting touch panel surface which may cause a short with the bottom layer. ② Keep the gap (over 0.3mm) between the bezel edge and touch panel surface. ③ We recommend the use of a cushion material between the touch panel and the bezel. ④ The cushion material should be limited only on the busbar area. If it is out of the busbar area, a short may occur.
Operation	<ul style="list-style-type: none"> ① Please do not operate touch panels by applying excessive force. ② Please do not use a sharp things except finger or R0.8 polyacetal tip pen for input. ③ We recommend calibration after long term use.

12. Others

12.1 This specification shall guarantee the quality of the product.

When using the products, be sure to check and evaluate after installing on your equipment.

12.2 After evaluation, please return approval sheet or our specification submitted, with approval stamp on it.

12.3 Any changes of the approved specification are subject to agreement prior to the actual changes.

Appendix 1 ; Linearity

Voltage (DC 5 volt) is applied to the top electrode.
 Output Voltage V(X) on the bottom electrode is measured at every crossing point.

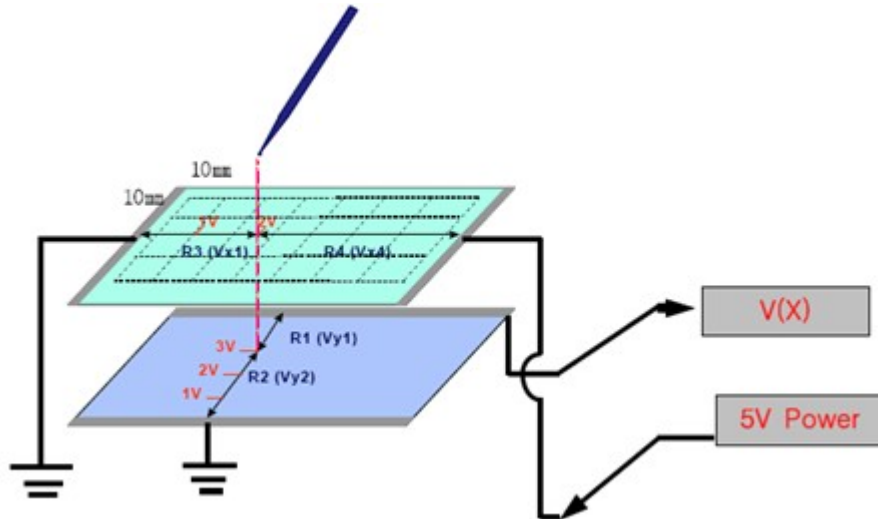

Linearity is measured by ;

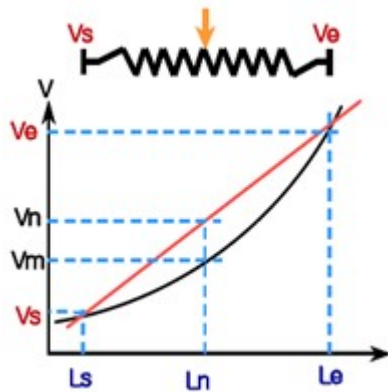

- Vs : Start voltage in the resistance
- Ve : End voltage in the resistance
- Ls : Starting point of resistance
- Le : Ending point of resistance
- Ln : Measuring point of resistance
- Vm: Measured voltage of Ln
- Vn : Expecting voltage of Ln
- Linearity = $\frac{[Vm-Vn] \times 100}{Ve-Vs}$

For the Y axis direction, exchange the Voltage Input direction, and measure the voltage in the same way.

REV No.	REVISED	DATE	DRAWN	CHECKED	APPROVED
0	NEW DRAW	07.10.22	S.J. BAE	J.B. ROH	H.J. CHAE

REV No.	REVISED	DATE	SCALE	DIM.	STD. TOL	DRAWING NO.	UNIT
0	NEW DRAW	07.10.22	1 : 1	1 : 1	±0.3	MD1021-MCD-AB	MM
						MD1021M-AB	MM

PRODUCT NO. **MD1021M-AB**

SIZE

APPROVED

REMARK

Glass Thk.	<input type="checkbox"/> 0.7mm	<input checked="" type="checkbox"/> 1.1mm
Film type	<input type="checkbox"/> Clear	<input checked="" type="checkbox"/> Non-glare
Total Thk.	<input type="checkbox"/> 0.95±0.15mm	<input checked="" type="checkbox"/> 1.35±0.15mm
Linearity	±1.5% or less	
Transmittance	80% or more	
Resistance	100< X axis < 1200 ohm	
	100< Y axis < 1200 ohm	
Tail	FPC(WI+Au)	
TFT-LCD MAKER	AUD(AT02W01 V4)	

CIRCUIT DIAGRAM

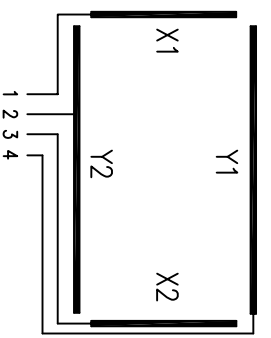

SIGNAL ASSIGNMENT

Pin No	Signal
1	X1
2	Y2
3	X2
4	Y1

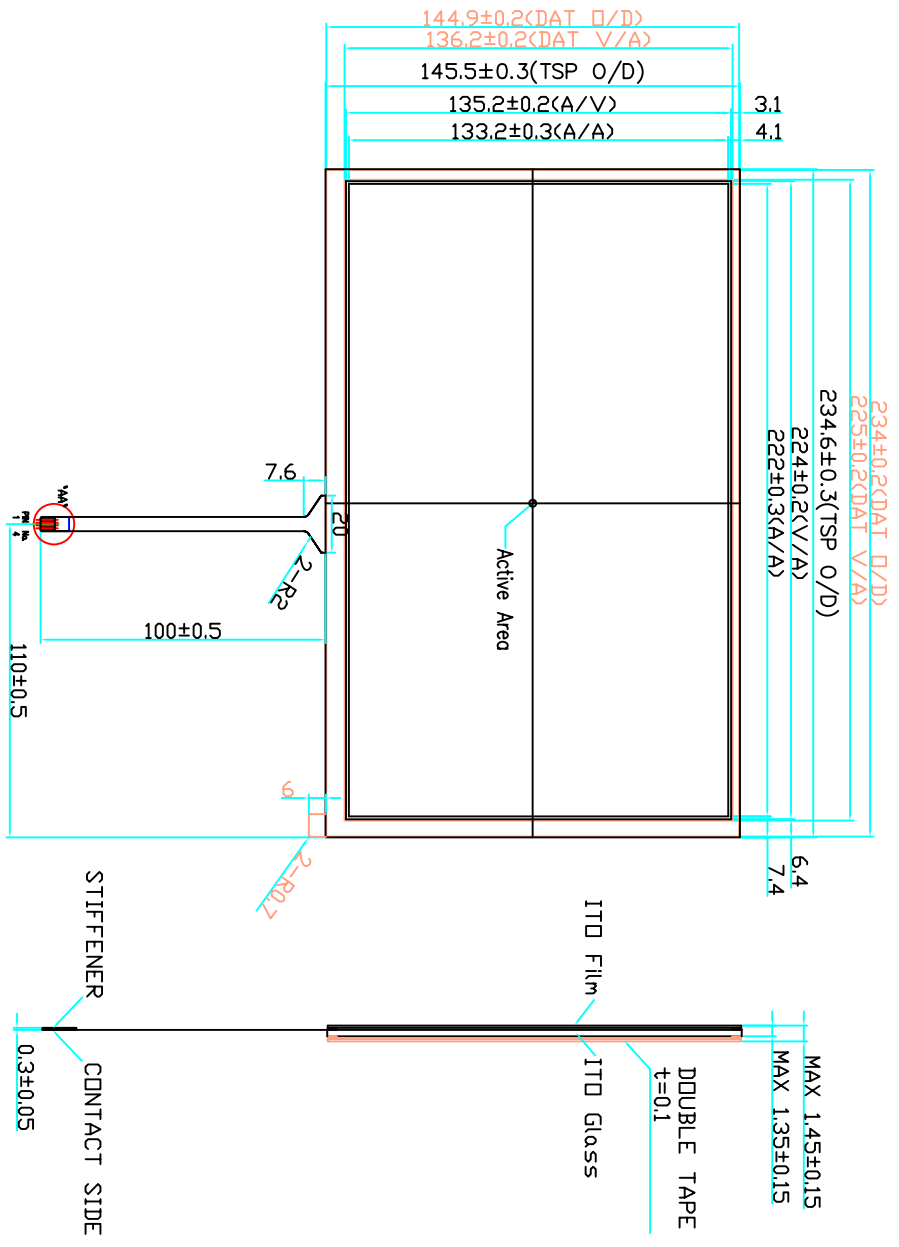

Detail "AA" (Scale=5/1)

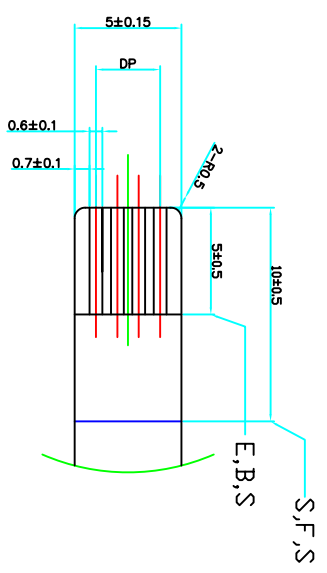

STIFFENER FRONT SIDE	S,F,S
EXPOSURE BACK SIDE	E,B,S

NOTICE OF PROPRIETARY PROPERTY

THIS DOCUMENT CONTAINS CONFIDENTIAL AND PROPRIETARY INFORMATION OF **meeredp** Co., Ltd. AND NEITHER IT NOR THE INFORMATION CONTAINED THEREIN SHALL BE DISCLOSED TO OTHERS OR DUPLICATED OR USED FOR OTHERS WITHOUT THE EXPRESS WRITTEN CONSENT OF **meeredp** Co., Ltd.